

PHF FX20-65X84

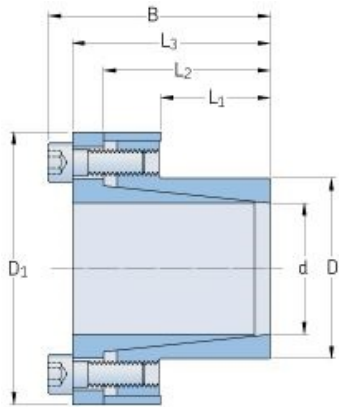

Bushing no.	FX20
d (mm)	65
d (in)	2.56
D (mm)	84
d_w (mm)	-
L (mm)	-
L_1 (mm)	55
L_2 (mm)	72
L_3 (mm)	80
B (mm)	88
D_1 (mm)	111
d_1 (mm)	-
e (mm)	-
F_t Transmissible axial force (kN)	94
M_t Transmissible torque (Nm)	3070
P_w Shaft surface pressure (N/mm ²)	70
P_n Hub surface pressure (N/mm ²)	55
Clamp screws Qty	9
Clamp screws size	M8
Clamp screws nut	-
M_s Screw tightening torque (Nm)	41
Weight (kg)	2.1