

PHE 1150TGHSET

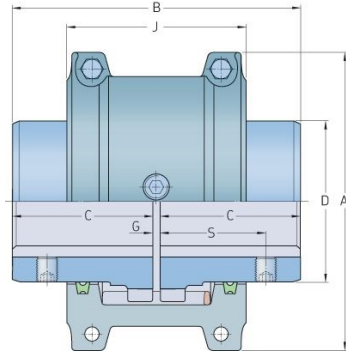

Size	1150
Power per 100 r/min (kW)	416
Power per 100 r/min (HP)	557.64
Nominal torque (Nm)	39800
Nominal torque (lbft)	29354.97
Max speed (r/min)	1500
Min. bore (mm)	108
Min. bore (in)	4.25
Max. bore (mm)	203
Max. bore (in)	7.99
Weight (kg)	234
Weight (lbs)	515.88
A (mm)	453.1
A (in)	17.84
B (mm)	371.8
B (in)	14.64
C (mm)	182.9
C (in)	7.2
D (mm)	269.2
D (in)	10.6
J (mm)	271.3
J (in)	10.68
F (mm)	391.2
F (in)	15.4
S	-
S (in)	-

® SKF is a registered trademark of the SKF Group

© SKF Group 2012

The contents of this publication are the copyright of the publisher and may not be reproduced (even extracts) unless prior written permission is granted. Every care has been taken to ensure the accuracy of the information contained in this publication but no liability can be accepted for any loss or damage whether direct, indirect or consequential arising out of the use of the information contained herein.

Gap G Min. (mm)	1.5
Gap G Min. (in)	0.06
Lubricant mass (kg)	1.95
Lubricant mass (lbs)	4.3
Coupling mass without bore (kg)	234
Coupling mass without bore (lbs)	515.88